



model TWBS.EW.H

Instantaneous Water Heater

FEATURES & BENEFITS

CONVENIENCE

Have the capability of on-demand hot water without the need of a large storage tank by incorporating this instantaneous water heater system.

SAFETY

Fail-safe measures include hot water shut off if the cold water supply is interrupted, and a cold-water bypass mode should the hot water get cut off.

OPTIONS

To see all options for this model, visit www.hawesco.com



SPECIFICATIONS

Model TWBS.EW.H on-demand, prepackaged, fully engineered and tested tempering system to provide tempered water instantaneously. System is designed to increase cold water temperature by a minimum of 34° F (19° C) at 4 gpm (15.1 L) flow and 68° F (38° C) at 2.0 gpm (7.5 L); thus it is suitable for single eyewash application. Outlet water temperature is factory set at 80° F (26° C). System consists of a UL listed 20 KW electrical instantaneous water heater, a hot shutoff valve, a bypass valve, an in-line 50 x 50 mesh filter, and an outlet temperature gauge. Requires 45 - 90 psi (3 - 6 ATM) flowing pressure. Inlet and Outlet: 1/2" IPS. Electrical Supply: 480 VAC, 3-phase, 3 wire and ground. 24 Amp per Phase. FOR INDOOR USE ONLY.

APPLICATIONS

Where the eyes of any person may be exposed to injurious or corrosive materials, emergency facilities for quick drenching or flushing of the eyes and body with tempered water is needed to compensate for less than suitable ambient temperatures, or when the supply water reaches freezing cold or scalding hot temperatures.



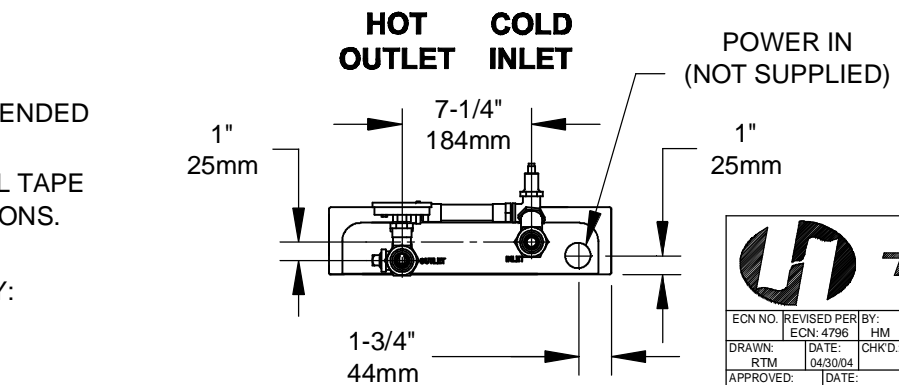
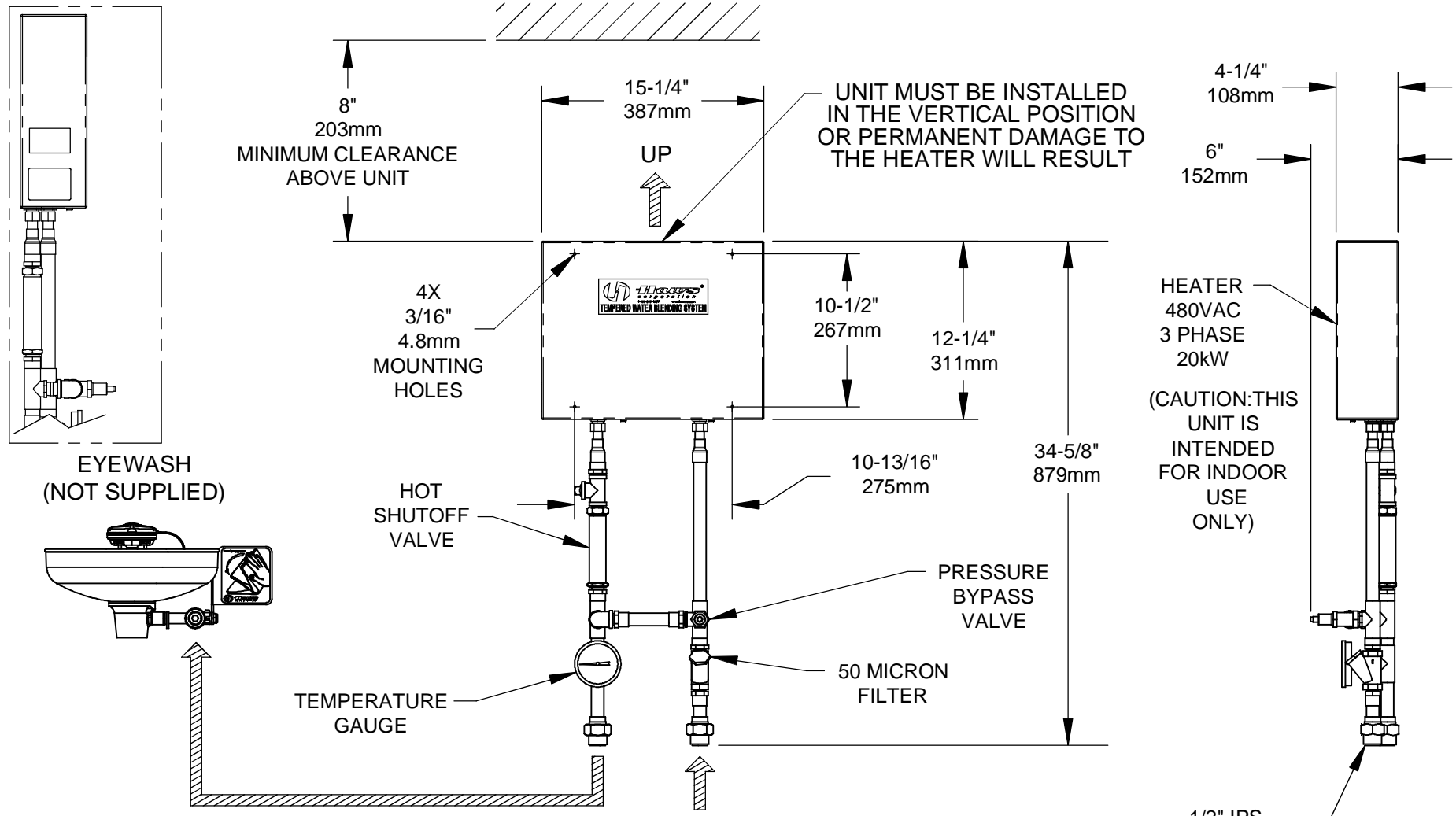

NOTES:

1. CAUTION: THIS UNIT IS INTENDED "FOR INDOOR USE ONLY"
2. USE TEFLON THREAD SEAL TAPE ON ALL WATER CONNECTIONS. **DO NOT USE PIPE DOPE.**
3. DIMENSIONS MAY VARY BY: ± 1/2" [12.7mm].



1455 KLEPPE LANE
 SPARKS, NEVADA 89431
 (775) 359-4712 FAX (775) 359-7424
 E-MAIL: HAWS@HAWS.CO.COM
 WEBSITE: WWW.HAWS.CO.COM

| | | | | |
|-------------------------|-----------|--------|-----------|--------------|
| ECN NO. REVISED PER BY: | ECN: 4796 | HM | MODEL(S) | |
| DRAWN: | DATE: | CHKD.: | | |
| RTM | 04/30/04 | | | |
| APPROVED: | DATE: | | | |
| | | | TWBS.EW.H | PART NUMBER |
| | | | | 0002080380.D |
| | | | | DRAWING NO. |
| | | | | 12681A00 |
| | | | | REV |
| | | | | 10 |